

BATTERY CHARGER TECHNICAL MANUAL

MODEL: Pb12060T

VERSION: V1.0

Contents

1. Revised History.....	1
2. Warning.....	1
3. Notes.....	1
4. Product Number System.....	2
5. Product Weight And Appearance.....	2
6. Indicator LEDs.....	3
7. Electronic Characteristics.....	3
8. Protect Characteristics.....	4
8.1 Output Over Voltage Protection.....	4
8.2 Output Over Current Protection.....	4
8.3 Short Circuit Protection.....	4
8.4 Reverse Polarity Protection.....	4
9. Environmental.....	4
9.1 Working Conditions.....	4
9.2 Storage Conditions.....	4
10. Reliability.....	5
11. Safety.....	5
11.1 Insulation Characteristics.....	5
11.2 Leakage Current.....	5
11.3 Standard specifies.....	5
11.4 Electromagnetic Interference.....	5
11.5 Electromagnetic Immunity.....	5

1. Revised History

Table 1. Revised History

Version	Detail	Date
V1.0	The initial version	03/25/2014

Remark: This table will be updated for product upgrade.

2. Warning

Please use the charger in accordance with the parameters and connections in the manual, and do not disassemble it. Or we will not be liable for the resulting loss.

3. Notes

- (1) High voltage inside the case, may cause harm to the human body. If the charger fails, please contact us. Users and non-professional maintenance staff is forbidden to open the charger.
- (2) Charger should not be used where in damp, water, direct sunlight or near heat sources.
- (3) Charger should be used where clean and well ventilated. Don't sheltered inlet or outlet during charging, and make sure that both inlet and outlet have air space of at least 10cm.
- (4) Charger should be used to prevent children closer and touch.
- (5) Is prohibited that the charger used or stored near flammable, explosive goods.
- (6) While cleaning the charger please do not wash with water, we recommend using a clean rag dipped a small amount of alcohol.

4. Product Number System

Pb - 12 060 - T

Housing T = Desktop / P = Plug-in
Charge current
Nominal voltage of battery pack
Series charger

5. Product Weight And Appearance

Umini series charger is about 0.5kg without input AC wire. Charger appearance as figure 1 below.

Size: 120mm×69mm×45mm



Figure 1. Appearance

Input AC wire is 150cm long with European plug(IEC 60884-1)
Output DC wire is 95cm long with RCA plug

Product label as shown in the following figure.

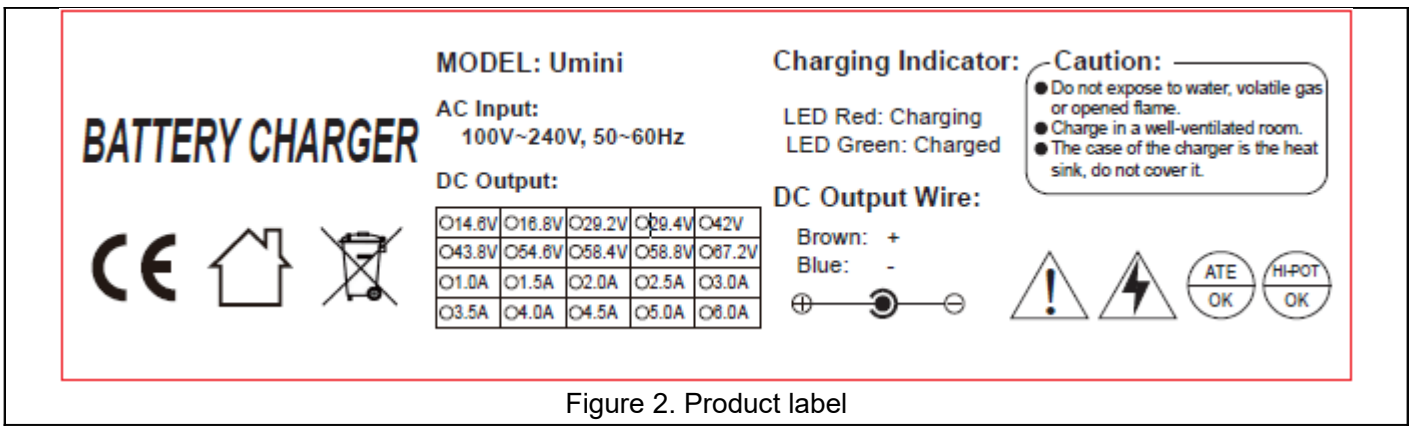

Figure 2. Product label

6. Indicator LEDs

Green: Charge complete, standby
Red: Charging

7. Electronic Characteristics

Table 3. Electronic characteristics

No.	Item	Unit	Min.	Typ.	Max.	Remark
01	Input voltage	Vac	90	110/220	264	
02	Input power	W	-	-	113	
03	Constant charge voltage	Vdc	14.4	14.7	15.0	
04	Float voltage(for lead acid battery only)	Vdc	13.5	13.8	14.1	
05	Constant charge current	A	5.8	6	6.2	
06	Charge complete current	mA	1700	1800	1900	
07	Ripple voltage	mV	-	-	250	
08	Efficiency	%	82	-	-	Full load

8. Protect Characteristics

1 Output Over Voltage Protection

When the charger output voltage exceeds the maximum charging voltage, the charger enters

the standby state protection. Troubleshooting can be automatically restored to normal working condition.

2 Output Over Current Protection

When the charger output current exceeds the maximum charging current, the charger enters the over current protection status. Troubleshooting automatically restored to normal working condition.

3 Short Circuit Protection

When the charger has short circuit at output, the charger enters short-circuit protection status. Troubleshooting automatically return to normal working condition.

4 Reverse Polarity Protection

If charger DC output terminal connect to battery reverse, fuse on the output side would be fuse, output circuit would be cut off. Replace the fuse, and then connect to battery correctly, charger would resume working.

9. Environmental

5 Working Conditions

Ambient temperature: $-5^{\circ}\text{C} \sim +40^{\circ}\text{C}$;

RH: 5% \sim 95%;

Max. altitude: 10000 meter;

Cooling: UY series chargers use of forced air cooling system. Under dustless and ventilated conditions, the full load temperature rise not exceeding 40°C .

6 Storage Conditions

Ambient temperature: $-40^{\circ}\text{C} \sim +70^{\circ}\text{C}$;

RH: 0% \sim 95%;

Max. altitude: 20000 meter.

10. Reliability

Table 4. Reliability

No.	Item	Description	Remark
01	MTBF	average operating life $\geq 30000\text{h}$	25°C
02	Anti-vibration	5mm/50Hz/600s vibration test	PASS

11. Safety

7 Insulation Characteristics

Table 5. Insulation characteristics

Insulation resistant	Input to output	DC500V 50MΩmin (25°C Humidity≤70%)
	Input to case	DC500V 50MΩmin (25°C Humidity≤70%)
	Output to case	DC500V 50MΩmin (25°C Humidity≤70%)
Hi-Pot	Input to output	1500Vac 50Hz 1minute ≤10mA
	Input to case	1500Vac 50Hz 1minute ≤10mA
	Output to case	500Vac 50Hz 1minute ≤10mA

8 Leakage Current

With max input and full load, the leakage current < 0.75m A, meet to Class II.

9 Standard specifies

EN 55022:2006+A1:2007

EN 61000-3-2:2006+A1:2009+A2::2009

EN 61000-3-3:2008

EN 55024:1998+A1:2001+A2:2003

10 Electromagnetic Interference

Conducted interference: EN55011.13.14-1.15.22.FCC part 15 & 18.VCCI;

Radiated interference: EN55011.13.22.FCCpart 15 & 18.VCCI/EN55013.EN55014-1.

11 Electromagnetic Immunity

Anti-static: IEC/EN61000-4-2 8KV;

Pulse group: IEC/EN61000-4-4 2KV;

Lightning surge: IEC/EN61000-4-5 1.5KV;

Harmonic: IEC/EN61000-3-2 <25%.