

LC-P1224PG/APG

FOR STANDBY POWER SUPPLIES.
 EXPECTED TRICKLE DESIGN LIFE: 10 – 12 YEARS
 AT 20°C ACCORDING TO EUROBAT.



G198049

DIMENSIONS (MM)



Terminal type (option)

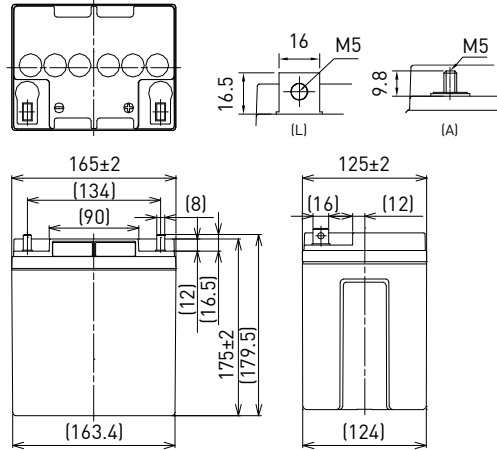

Contents indicated (including the recycle marking, etc.) are subject to change without notice. Battery case resin: flame-retardant (UL94 V-0)

Specifications		LC-P1224PG/APG
Nominal voltage (V)		12
Nominal capacity	20 hours rate (Ah)	24.0
	Length (mm)	125
Dimensions	Width (mm)	165
	Total height (mm)	179.5/175
	Approx. mass (kg)	8.05
Terminal type	M5 bolt/nut & threaded post	
Capacity (25°C)	20 hours rate (Ah)	24.0
	10 hours rate (Ah)	22.0
	3 hours rate (Ah)	18.0
	1 hour rate (Ah)	14.0
Impedance (mΩ)	Fully charged battery (25°C)	11
	40°C	102
Temperature dependency of capacity (%) – 20 hours rate	25°C	100
	0°C	85
	-15°C	65
	Remaining capacity (25°C)	After 3 months (%)
After 6 months (%)		82
After 12 months (%)		64

DURATION OF DISCHARGE VS. DISCHARGE CURRENT

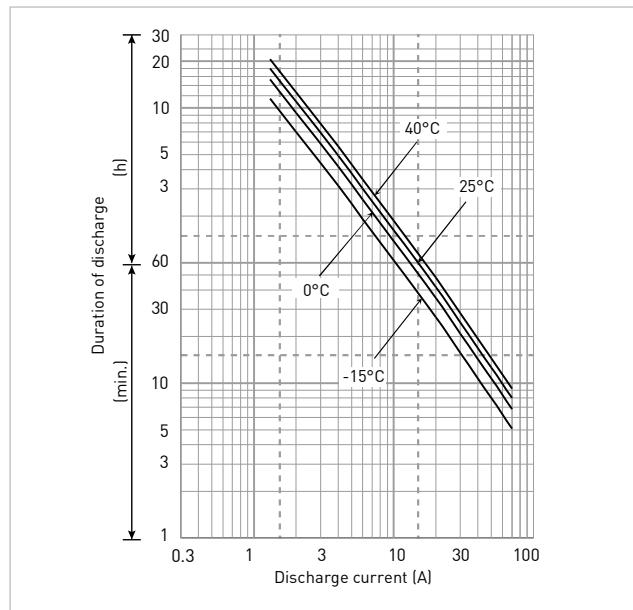

WATT TABLE (25°C)

(Wattage/battery)

Cut-off	5min.	10min.	15min.	20min.	30min.	45min.	1h	1.5h	2h	3h	4h	5h	6h	10h	20h
9.6V	992	739	523	441	317	234	183	118	104	73.8	58.6	47.9	40.8	26.4	14.6
9.9V	931	724	520	434	314	232	181	116	103	73.4	58.2	47.5	40.6	26.3	14.6
10.2V	872	706	509	426	310	230	179	113	101	72.7	57.8	47.2	40.3	26.0	14.5
10.5V	782	654	474	405	303	226	175	111	97.2	71.6	57.4	46.8	39.8	25.9	14.4
10.8V	691	583	442	394	293	223	172	108	92.6	70.1	56.6	45.6	39.2	25.6	14.3

AMPERE TABLE (25°C)

(Ampere/battery)

Cut-off	5min.	10min.	15min.	20min.	30min.	45min.	1h	1.5h	2h	3h	4h	5h	6h	10h	20h
9.6V	89.0	66.0	45.5	38.0	27.1	19.9	14.6	10.0	8.80	6.20	4.90	3.89	3.40	2.27	1.23
9.9V	83.5	64.7	45.2	37.4	26.8	19.8	14.5	9.80	8.73	6.17	4.87	3.86	3.39	2.26	1.22
10.2V	78.2	63.0	44.3	36.8	26.5	19.6	14.3	9.60	8.51	6.11	4.84	3.83	3.36	2.23	1.21
10.5V	70.1	58.4	41.2	34.9	25.9	19.3	14.0	9.40	8.21	6.01	4.80	3.80	3.32	2.22	1.20
10.8V	62.0	52.1	38.4	34.0	25.0	19.0	13.7	9.14	7.82	5.89	4.74	3.71	3.27	2.20	1.19

All mentioned values are average values

LC-P1224PG/APG

CHARGING METHOD (25°C)

Cycle use	Control voltage: 13.6V - 13.8V Initial current: 3.6A or smaller
------------------	--

CUT-OFF VOLTAGE

Discharge current	1.2A - 4.8A	4.8A - 12A	12A - 24A	24A - 48A	48A - 72A
Cut-off voltage	10.5V	10.2V	9.9V	9.3V	8.7V

INFLUENCE OF TEMPERATURE ON TRICKLE LIFE

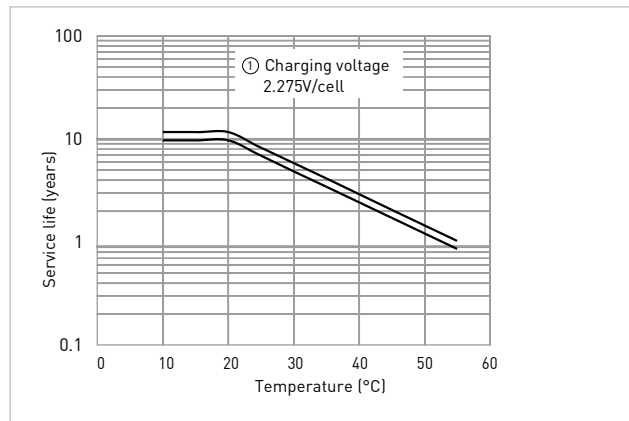

RESIDUAL CAPACITY VS. STORAGE PERIOD

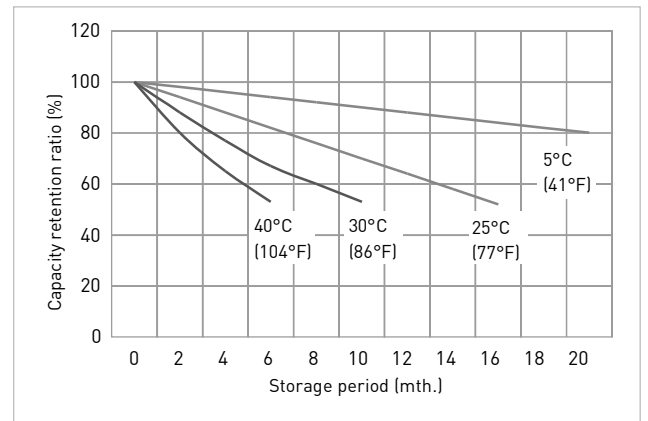

CONSTANT-VOLTAGE CONSTANT-CURRENT CHARGE CHARACTERISTICS FOR TRICKLE USE

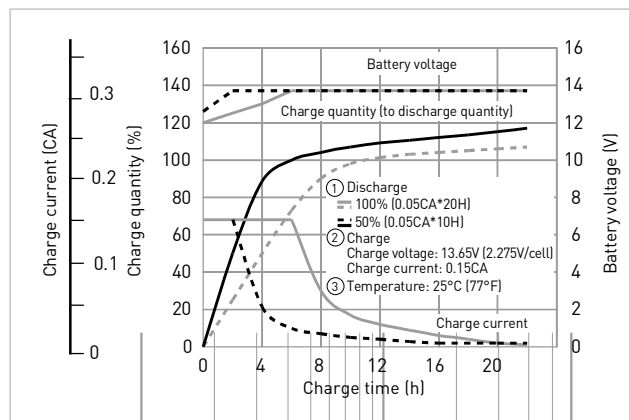

DISCHARGE CAPACITY BY TEMPERATURE AND BY DISCHARGE CURRENT

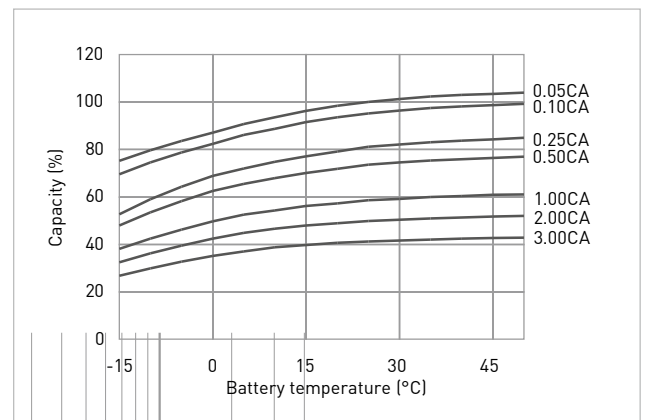

DISCHARGE CHARACTERISTICS

