

APPLICATIONS

Mobile Home Equipment
Marine Applications
Personal Carriers
Cleaning Machines
Utility Vehicles

SPECIFICATIONS

Nominal Voltage	12V	
Nominal capacity @20 hour rate	220Ah	
Capacity at 25°C	10 hour rate	200Ah
	5 hour rate	180Ah
	1 hour rate	125Ah
Shelf time @20°C up to 70%	in months	9
Internal resistance (at 1 KHz)	approx. 2,7 mΩ	
Operating temperature for (dis)charge	-15°C to + 40°C	

DIMENSIONS

Dimensions LxWxH (T) in mm	522x240x219 (225)
Weight	65kg (±2%)
Separator	AGM, Glass Matt
Case and cover	ABS
Terminal	M8
Torque setting (recommended)	M8 (Copper): 8 Nm
Maximum allowable torque value	M8 (Copper): 10 Nm

CHARGING

Charging Voltage cycle use 14,4 to 14,9 Volt
Float charge Voltage 13,6 to 13,8 Volt
Charging current, minimum 25A - maximum 38A

CYCLE LIFE

To maximize the cycle life of the battery, we recommend to charge the battery fully after use. The total life of the battery, is very dependant on the correct charge and depth of discharge per cycle.

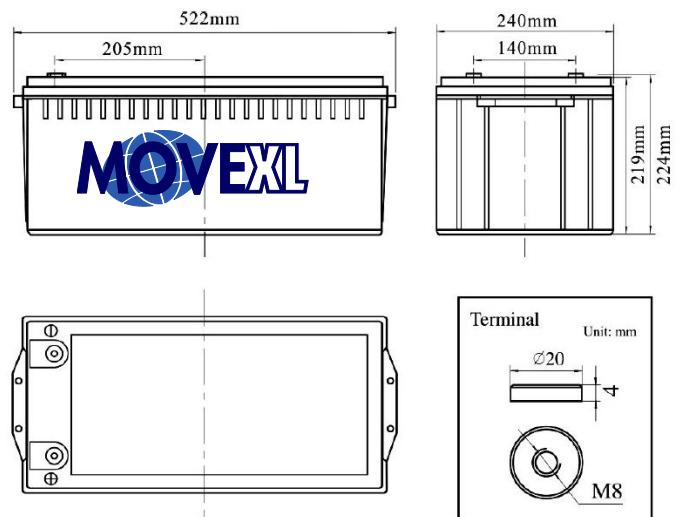

BATTERY LIFE UNDER CYCLIC USE

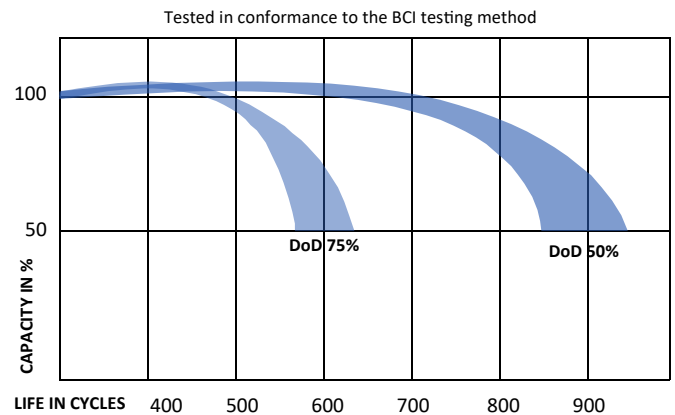

* Cycle life is measured with a discharge current 0,2C, charged 16h and rest capacity of 2/3 Cn