

## H-AAA700B

### Specifications of single cell

Nominal voltage		1.2 V	
Capacity		0.2 C Discharge	1.0 C Discharge
	Minimum	700 mAh	665 mAh
	Typical	735 mAh	688 mAh
Dimensions	Diameter	mm	
		10.5 <sup>-0.7</sup>	
	Height	44.5 <sup>-1.0</sup>	
Weight (approximately)		gram	
		11.3	
Internal Impedance at 1000 Hz		30 mΩ (max) After Charge	
Charge	Standard	70 mA (0.1 C) × 15 h	
	Rapid	700 mA (1.0 C) × 1.1 h	
Ambient temperature	Charge	Standard	°C
			0°C to 40°C
	Rapid	0°C to 40°C	
	Discharge	-20°C to 50°C	
	Storage	-20°C to 30°C	

### Dimensions with tube (unit mm)

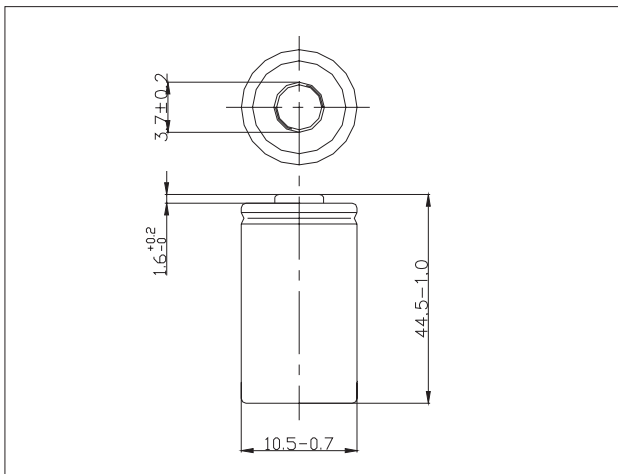

Note:

1. Nominal capacity, rated at 0.2 C 20°C.
2. Average capacity, for reference only.
3. Weight and internal impedance are for reference.
4. Standard according as IEC of test cycle life.

### Typical characteristics

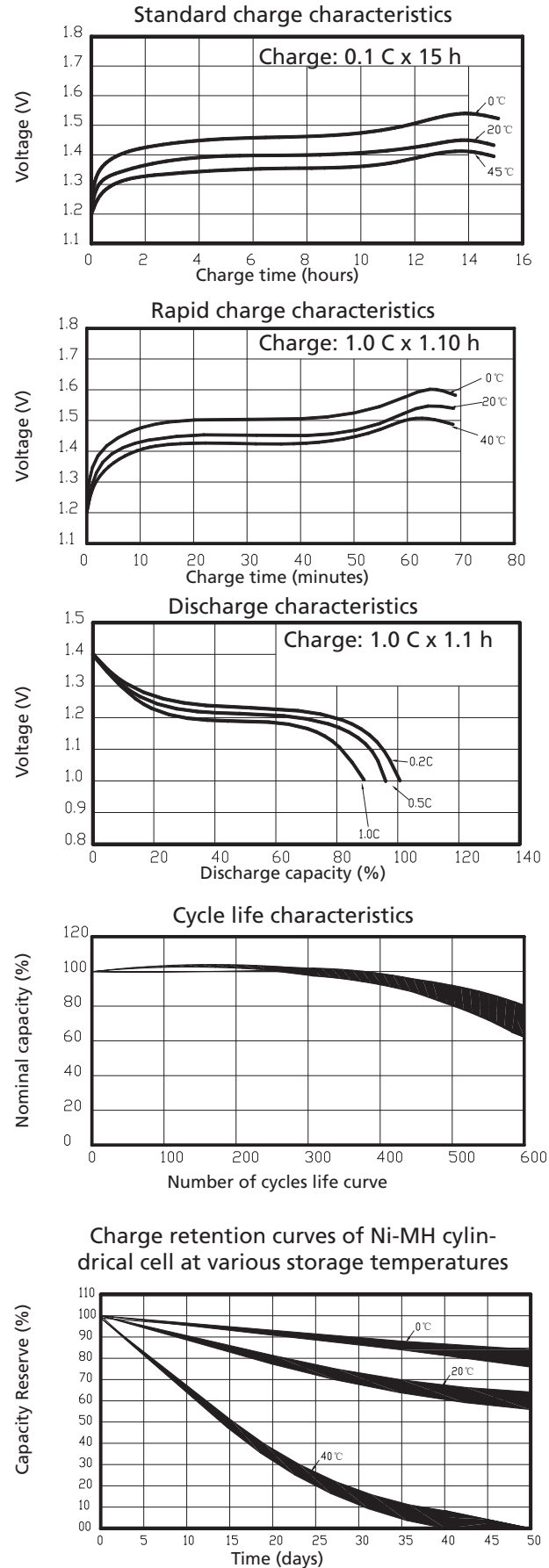

## 1. RATINGS

Description	Unit	Specification	Condition
Nominal Voltage	V	1.2	Unit cell
Typical Capacity	min	315	Standard Charge/Discharge
Nominal Capacity	mAh	700	Standard Charge/Discharge
Minimum Capacity	min	300	Standard Charge/Discharge
Standard Charge	mA	70 (0.1 C)	Ta = 0~40°C (see note 1)
	hour	15	
Fast Charge	mA	140 (0.2 C)~700 (1.0 C) with charge termination control	-ΔV = 5 mV/cell Timer cutoff = 110 % input capacity Temp. cutoff = 40~45°C dT/dt = 0.8°C/min (0.5 to 1.0 C); 0.8~1°C/min (1 C)
	hour	6.0 approx. (0.2 C) 1.1 approx. (1.0 C)	
Trickle Charge	mA	35 (0.05 C)~70 (0.1 C)	Ta = 0~40°C (see note 1)
Discharge Cut-off Voltage	V	1.0	Unit cell
Maximum Discharging Current	mA	2100 (3.0 C)	Ta = 0~50°C 0.8 V cut off
Storage Temperature	°C	-20~+25 (within 1 year) -20~+30 (within 3 month) -20~+40 (within 1 month) -20~+50 (within 1 week)	*
Typical Weight	g	11.3 approx.	*

## 2. PERFORMANCE

Ambient temperature: 20±5°C

Relative Humidity: 65±20 %

Note Standard Charge/Discharge Conditions:

Charge: 70 mA (0.1 C) x 15 h

Discharge: 140 mA (0.2 C) to 1.0 V/cell

Test	Unit	Specification	Condition	Remarks
Capacity	min	≥ 300	Standard Charge/Discharge	Up to 3 cycles are allowed.
Open circuit Voltage (OCV)	V	≥ 1.25	Within 1 h after standard charge	Unit cell
Internal Impedance (Ri)	mΩ	≤ 30	Upon fully charge at 1 kHz	*
High Rate Discharge (1.0 C)	min	≥ 57	Standard Charge/rest 30 min discharge at 1.0 C to 1.0 V	Up to 3 cycles are allowed.
High Rate Discharge (3.0 C)	min	N/A	Standard Charge/rest 30 min discharge at 3.0 C to 0.8 V	Up to 3 cycles are allowed.
Low Temperature Discharge	min	≥ 240	Standard Charge, Storage 24 h at 0±2°C 0.2 C discharge at 0±2°C	1.0 V/cell Cut-off
Overcharge	N/A	No conspicuous deformation and/or leakage	0.1 C charge for 48 h	*
Charge reserve	min	≥ 180 min	Standard charge Storage: 28 days, Standard discharge (0.2 C)	1.0 V/cell Cut-off

IEC Cycle Life Test	Cycle	≥ 500	IEC61951-2(2003)7.4.1.1	*
Humidity	N/A	No leakage	Standard charged, stand for 14 days at 33±3°C and 80±5% of relative humidity.	*
External Short Circuit	N/A	No fire and no explosion	After standard charge, short-circuit the cell at 20°C±5°C until the cell temperature returns to ambient temperature (cross section of the wire or connector should be more than 0.75 mm <sup>2</sup> ).	*
Safety Device Operation	N/A	No explosion	Forced discharge at 0.2 C to a final voltage of 0 V, then the current be increased to 1 C and forced discharge continue for 60 min.	Leakage of electrolyte and Deformation are acceptable.
Free falling (drop)	N/A	$\Delta V < 0.02$ V/cell $\Delta Ri < 5$ %/cell	Charge at 0.1 C for 16 h, and then leave for 24 h, check battery before/after drop. Height: 50 cm Thickness of wooden board: 30 mm Direction is not specified. Test for 3 times.	*

## Notes:

1. Ta: Ambient Temperature
2. Approximate charge time from discharged state, for reference only.
3. Please activate the battery once every 3 months according to the following method: Charge at 0.1 C for 15 h, rest 10 min, then discharge with 0.2 C to 1.0 V/cell, rest 10 min, then charge at 0.2 C to 150 min.

**3. PRECAUTIONS TO ENSURE THE SAFETY ON BANDING BATTERY:**

1. Batteries should be charged prior to use.
2. When using a new battery for the first time or after long term storage, please fully charge the battery before use.
3. For charging methods please reference to our technical handbook.
4. Use the correct charger for Ni-Cd or Ni-MH batteries.
5. Do not reverse charge batteries.
6. Do not short circuit batteries, permanent damage to batteries may result.
7. Do not incinerate or mutilate batteries, may burst or release toxic material.
8. Do not solder directly to cells or batteries.
9. Do not subject batteries to adverse condition such as extreme temperature, deep cycling and excessive overcharge/overdischarge.
10. Store batteries in a cool dry place.
11. Do not mix XCell batteries with other battery brands or batteries of a different chemistry such as alkaline and zinc carbon.
12. Do not mix new batteries in use with semi-used batteries, overdischarge may occur.
13. Avoid batteries being used in an airtight compartment. Ventilation should be provided inside the battery compartment; otherwise batteries may generate hydrogen gas, which could cause an explosion if exposed to an ignition source.
14. When connecting a battery pack to a charger, ensure correct polarity.
15. If find any noise, excessive temperature or leakage from a battery, please stop its use.
16. When the battery is hot, please do not touch it and handle it, until it has cooled down.
17. Do not remove the outer sleeve from a battery pack nor cut into its housing.
18. When find battery power down during use, please switch off the device to avoid overdischarge.
19. When not using a battery, disconnect it from the device.
20. Unplug a battery by holding the connector itself and not by pulling at its cord.
21. After use, if the battery is hot, before recharging it, allow it to cool in a well-ventilated place out of direct sunlight.
22. Never put a battery into water or seawater.
23. During long term storage, battery should be charged and discharged once every half a year.

24. Do not attempt to take batteries apart or subject them to pressure or impact. Heat may be generated or fire may result. The alkaline electrolyte is harmful to eyes and skin, and it may damage clothing upon contact.
25. Keep away from children. If swallowed, contact a physician at once.

#### 4. APPEND: IEC61951 4.4 Endurance in cycles

Before the endurance in cycles test, the cell shall be discharged at 0.2 I<sub>A</sub> to a final voltage of 1.0 V/cell. The following endurance test shall then be carried out, irrespective of cell designation, in an ambient temperature of 20°C ± 5°C. Charge and discharge shall be carried out at constant current throughout, using the conditions specified in table 5. Precautions shall be taken to prevent the cell-case temperature from rising above 35°C during the test, by providing a forced air draught if necessary.

NOTE: Actual cell temperature, not the ambient temperature, determines cell performance.

Table 5-Endurance in cycles

Cycle number	Charge	Stand in Charged condition	Discharge
1	0.1 C <sub>10</sub> A for 16 h	None	0.25 C <sub>10</sub> A for 2 h 20 min <sup>2)</sup>
2 to 48	0.25 C <sub>10</sub> A for 3 h 10 min	None	0.25 C <sub>10</sub> A for 2 h 20 min <sup>2)</sup>
49	0.25 C <sub>10</sub> A for 3 h 10 min	None	0.25 C <sub>10</sub> A to 1.0 V/cell
50	0.1 C <sub>10</sub> A for 16 h	1 h to 4 h	0.2 C <sub>5</sub> A to 1.0 V/cell
<ul style="list-style-type: none"> <li>It is permissible to allow sufficient open-circuit rest time after the completion of discharge at cycle 50, so as to start cycle 51 at an exact two-week interval. A similar procedure may be adopted at cycles 100, 150, 200, 250, 300, 350, 400 and 450.</li> <li>If cell discharge voltage drops below 1.0 V/cell, discharge may be discontinued.</li> </ul>			

Cycles 1 to 50 shall be repeated until the discharge duration on any 50<sup>th</sup> cycle becomes less than 3 h at this stage, a further cycle as specified for cycle 50 shall be carried out. The endurance test is considered complete when two such successive cycles give a discharge duration less than 3 h. The number of cycles obtained when the test is completed shall be not less than 500.