

To PECE

Specifications

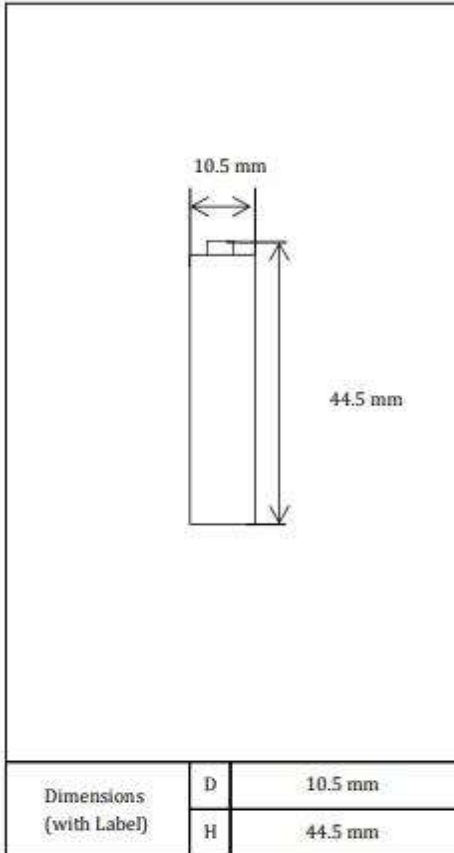

Type : Nickel-Metal Hydride Battery		Size : AAA Consumer Type
Country of origin		Japan
Capacity ¹⁾	Minimum	930mAh
Nominal Voltage		1.2V
Charging Current x Time	Fast Charge ²⁾	Max.480mA
Ambient Temp.	Charge Condition	Fast Charge ²⁾
	Discharge Condition	0°C - 40°C
	Storage Condition	Less than 90days
Less than 1year		-20°C - 30°C
Internal Impedance ³⁾ (after discharge to E.V.=1.0V)		Approx. 45mΩ (at 1000Hz)
Weight ⁴⁾		Approx. 13 g
Size ⁴⁾ : (Diameter) x (Height)		10.5(D) x 44.5(H) mm

- 1) Single cell capacity under the following condition.
Charge: 93 mA x 16h, Discharge: 186 mA (E.V = 1.0V at 20deg. C)
- 2) Use recommended of charging system
- 3) After a few charge and discharge cycles under the above first condition.
- 4) With label

Charge Characteristics

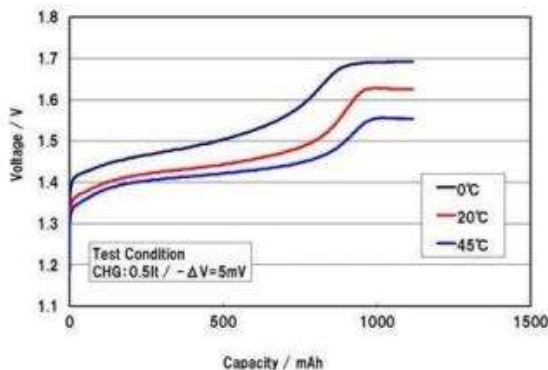

Discharge Characteristics

