

## CPH 95-12

## High Rate AGM battery

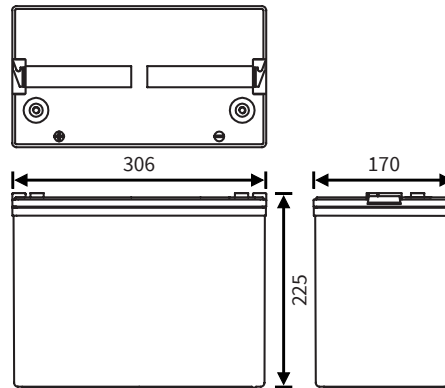

### Dimensions (mm)



### Standard terminal

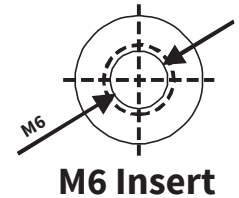

### Typical applications

- UPS systems
- Data centers
- Telecom systems
- Security systems
- Emergency lighting
- Air traffic power stations
- Medical equipment
- Solar energy

### Features

- Valve Regulated Lead Acid (VRLA)
- Maintenance free
- Absorbent Glassmat Technology (AGM)
- Built to comply with DIN 43534, IEC8962, BS6290-pt.4
- Low self discharge
- Classified as non-spillable under IATA, ADR and IMDG regulations
- Can be discharged or stored in any position without leakage
- Battery cannot be charged while upside down
- Produced under ISO 9001 & ISO 14001

Nominal voltage	12 V
Nominal capacity (1.80V/c, 25°C)	20Hr: 94.0 Ah 1Hr: 60.5 Ah
Nominal power (1.60V/c, 25°C)	10Min: 525.0 W/cell
Internal resistance	≤4.4mΩ (fully charged)
Maximum charge current	28.2 A
Maximum discharge current	810 A (max. 5 sec)
Float use / cyclic use	13.5V - 13.8V / 14.4V - 14.7V
Self discharge	Lower than 3% per month
Operating temperature range	-20°C ~ 60°C
Designlife (20°C)	10-12 years in float (Eurobat)
Standard terminal	Insert M6 (8.5 Nm Torque)
Housing material	ABS (UL 94-HB)
Dimensions Length	306 mm
Dimensions Width	170 mm
Dimensions Height	225 mm
Approximate Weight	29.2 kg
Packing	1 pcs / box

### Constant Current Discharge (Amps) at 25 °C (77°F)

FV/TIME	3 Min	5 Min	10 Min	15 Min	20 Min	25 Min	30 Min	45 Min	60 Min
1.80V/cell	397,0	318,0	236,0	188,0	156,0	137,0	120,0	82,6	60,5
1.75V/cell	408,0	339,0	245,0	194,0	167,0	144,0	125,0	84,0	63,2
1.70V/cell	425,0	352,0	251,0	200,0	171,0	148,0	129,0	86,1	65,1
1.67V/cell	439,0	362,0	264,0	210,0	179,0	156,0	137,0	99,3	67,7
1.65V/cell	441,0	366,0	270,0	211,0	180,0	158,0	139,0	99,5	68,7
1.60V/cell	446,0	376,0	286,0	215,0	182,0	161,0	145,0	100,0	71,2

### Constant Power Discharge (Watts) per Cell\* at 25 °C (77°F)

FV/TIME	3 Min	5 Min	10 Min	15 Min	20 Min	25 Min	30 Min	45 Min	60 Min
1.80V/cell	708,0	567,0	427,0	344,0	296,0	258,0	221,0	159,0	121,0
1.75V/cell	764,0	607,0	457,0	358,0	311,0	264,0	226,0	164,0	125,0
1.70V/cell	821,0	642,0	487,0	390,0	321,0	274,0	235,0	170,0	132,0
1.67V/cell	854,0	672,0	497,0	400,0	331,0	284,0	245,0	181,0	137,0
1.65V/cell	860,0	686,0	505,0	403,0	336,0	289,0	249,0	182,0	138,0
1.60V/cell	874,0	719,0	525,0	412,0	349,0	300,0	259,0	187,0	141,0

\*: Battery consists of 6 cells

## Charge characteristics

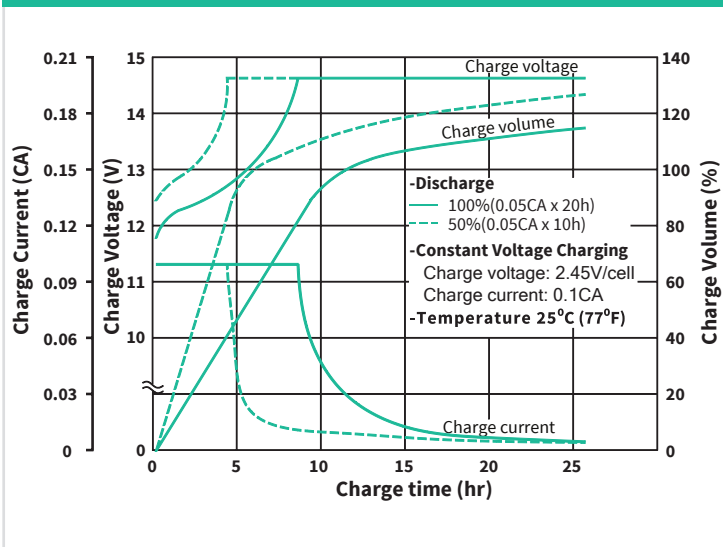

## Discharge characteristics

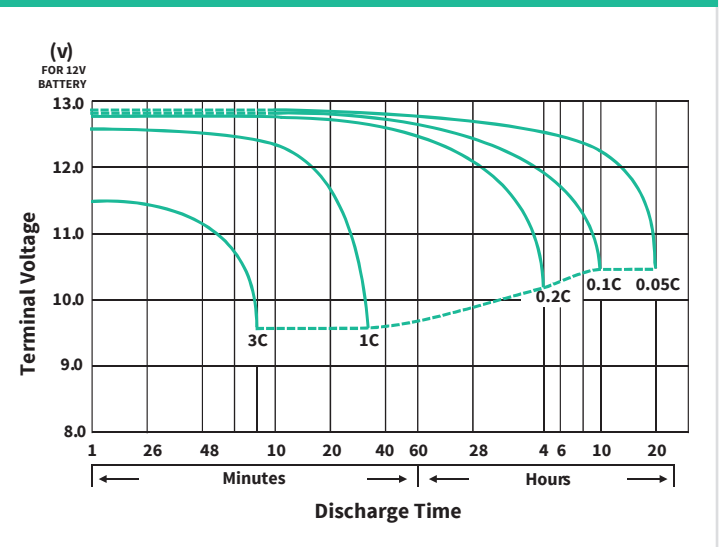

## Charge voltage in relation to temperature

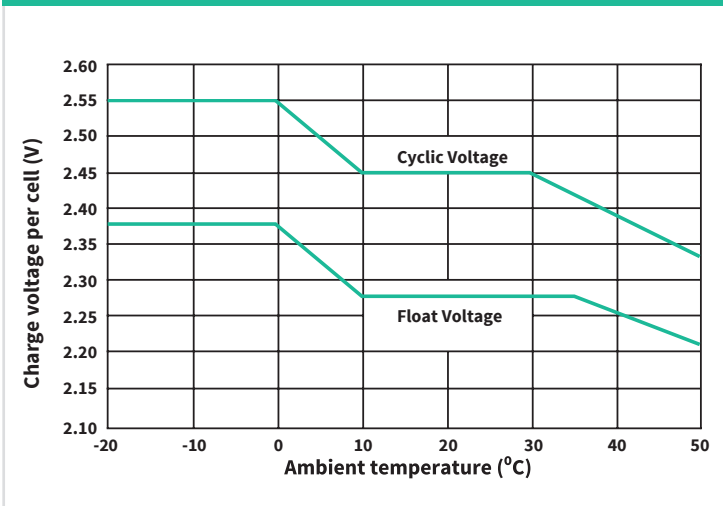

## Service life in relation to temperature

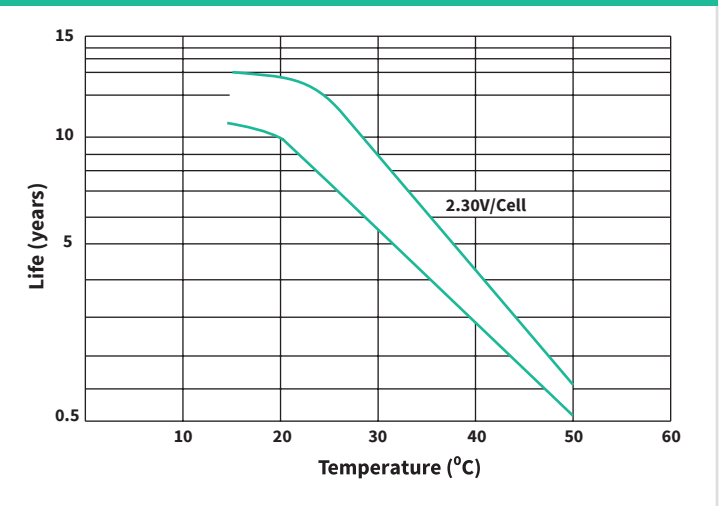

## Models available

Model	Voltage	Capacity (Ah)	Dimensions (mm)	Weight (kg)
CPH 5-12	12	5	90x70x107	1.90
CPH 6-12	12	6	151x51x101	2.00
CPH 80-12	12	80	258x166x215	24.50
CPH 95-12	12	95	306x170x225	29.20
CPH 110-12	12	110	339x173x220	31.50
CPH 140-12	12	140	341x173x283	39.50
CPH 150-12	12	150	341x173x283	41.00

## Cellpower family

Cellpower supplies a broad range of reliable AGM, GEL and Lithium batteries. Each product series has its own unique characteristics, so that there is a suitable battery for every application with its associated specific usage profile. Combined with the right Cellpower battery accessories, you are able to assemble a high-quality and reliable battery system.

The sealed, maintenance-free AGM lead battery type has a long operational lifetime. When used correctly, the Absorbed Glass Mat (AGM) technology offers dependable, lasting service. Additionally, AGM batteries exhibit very little self-discharge when compared with other lead-acid batteries. Sealed lead-acid batteries require low maintenance and do not need to be refilled with water or other liquids.

